

DeckRail

A Product of DeckRite LLC
3912 East Progress
North Little Rock, AR 72114
Phone: (501) 945-1919
Fax: (501) 604-0235



Deck Rite Welded Picket Railing Installation Guide

Disclaimer:

This guide is not intended to replace a trained professional installer. The drawings and instructions contained within are for demonstration purposes only. All Uses of this product are to conform with local building codes. Proper safety precautions and safe work practices should be followed at all times while installing this product. Deck Rite does not accept any liability for any damages, except as noted in the warranty.

Tools Needed to Install

- Miter saw and carbide-tipped blade
- Power drill
- Tape measure
- Level
- Safety goggles and hearing protection
- Extension cords
- Drill bits
- #2 and #3 square driver bits
- Pencil
- Angle finder

Diagram A

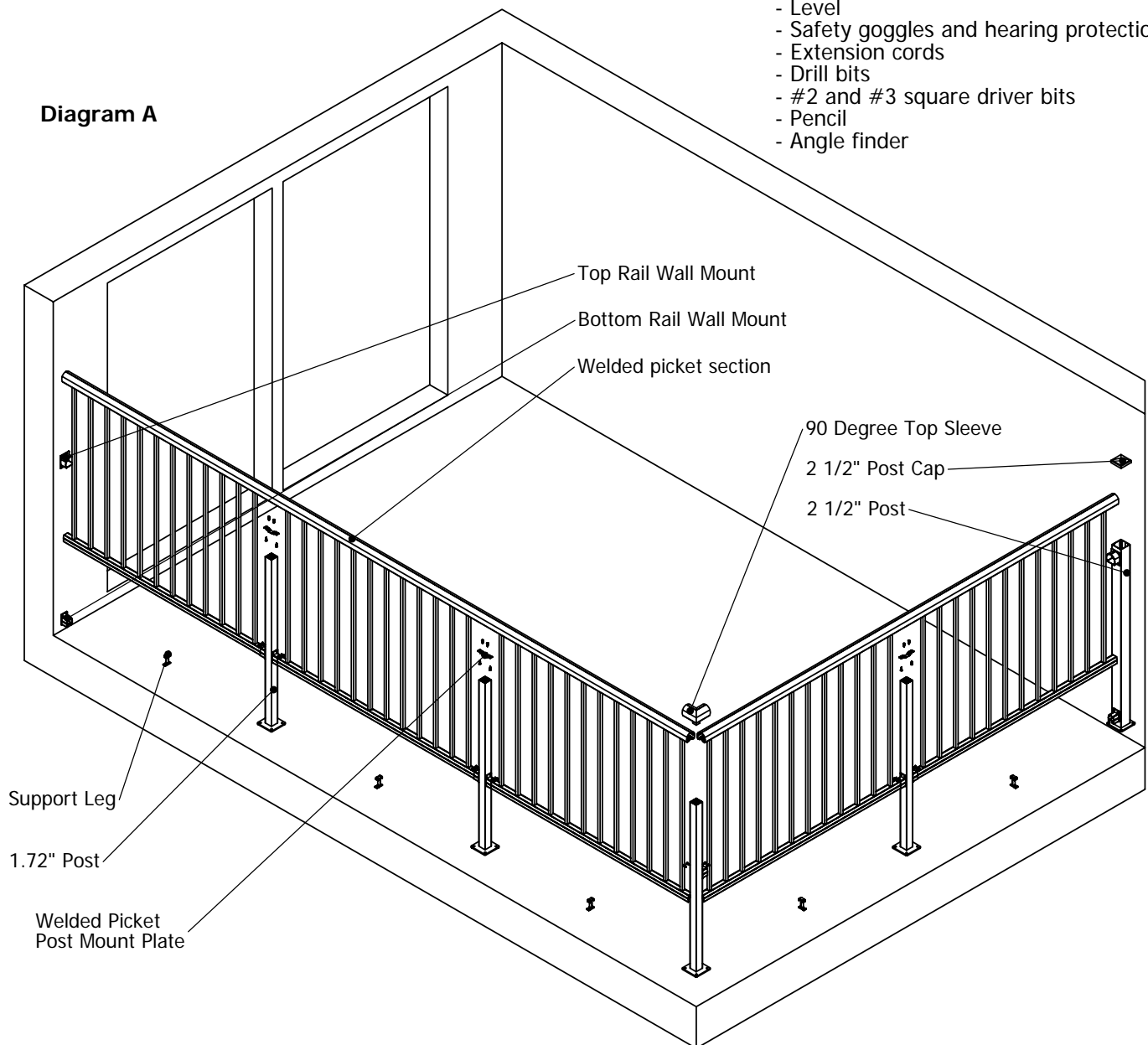

THE MATERIAL CONTAINED HEREIN IS PROPRIETARY TO DECKRITE LLC. AND SHALL NOT BE REPRODUCED, DISCLOSED, OR USED FOR ANY OTHER PURPOSE WITHOUT THE WRITTEN CONSENT OF DECKRITE LLC.

DeckRail

A Product of DeckRite LLC
3912 East Progress
North Little Rock, AR 72114
Phone: (501) 945-1919
Fax: (501) 604-0235



Installation Notes:

- Review the deck and figure out your approximate post locations. A solid mounting surface is required at all post locations. Most railing is installed with a three Inch centerline from the deck edge, but this can be adjusted to suit site specifications.
- Ensure that you have a solid mounting surface at any location where the railing will be wall mounted to a building or similar structure.
- Posts may require a shim to be placed underneath them to keep the railing level on a sloping deck
- Any post that will have an outside sleeve on top may have to be trimmed in order to maintain a consistent rail height.
- Drain holes in the posts should run in the same direction as the railing.

Before installing check your local building codes to ensure you will meet any special code requirements for your area.

Common rail heights are either 36" or 42". The distance between posts will vary depending on the job site.

Step 1

Determining Sleeve Posts

Trim any posts that require a post sleeve to be installed. The overall post height should be 1/8 of an inch less than posts that use a post mount plate. (Or be 2" Closer to the deck than the desired rail height.) Loosely install the sleeve on top of the post, but do not yet fasten them to the post. See Diagram B.

Step 2

Installing Post Mount Plates

Any Post that does not have a top sleeve will require a post mount plate to be installed. Using 2 - #10 X 3/4" Tek screws, screw the post mount plates on top of the remaining posts. See Diagram C.

Diagram B

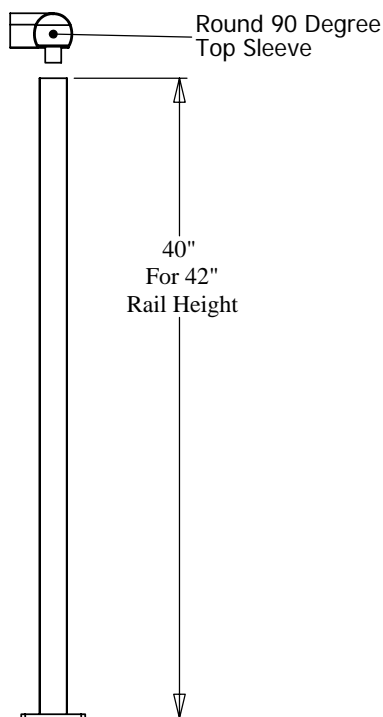
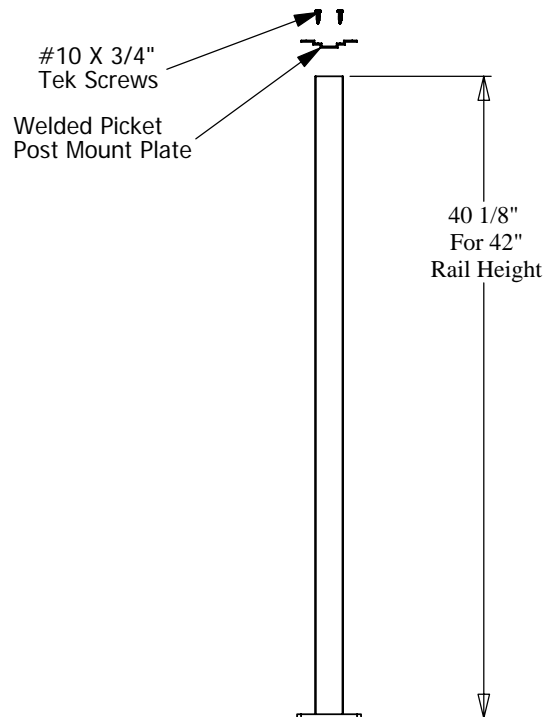

Diagram C



DeckRail

A Product of DeckRite LLC
3912 East Progress
North Little Rock, AR 72114
Phone: (501) 945-1919
Fax: (501) 604-0235



Step 3

Determine Sleeve Post Locations

Each sleeve post and end post will need to be temporarily installed. This is done to determine cut sizes for the welded picket panel. There should not be more than a 4" gap between the wall and any end posts. For surface mount railing a common baseplate location is 1" from the edge of the deck to the edge of the baseplate. Fascia mount railing will vary depending on site conditions.

Step 4

Determine Panel Cut Sizes and Mid Post Locations.

Measure the openings between sleeve posts, and between the wall and the sleeve post. Determine your panel cut sizes, allow 1/2" at each location that gets a sleeve. For each mid post you will need to cut out a picket. This is done by cutting the bottom rail 1/2" from the post edge and then breaking the weld on the top rail. See Diagram D.

Note:

The instructions given are for installation using bottom wall mounts. If you are using rail clips you must cut the bottom rail to the exact width of the post being installed.

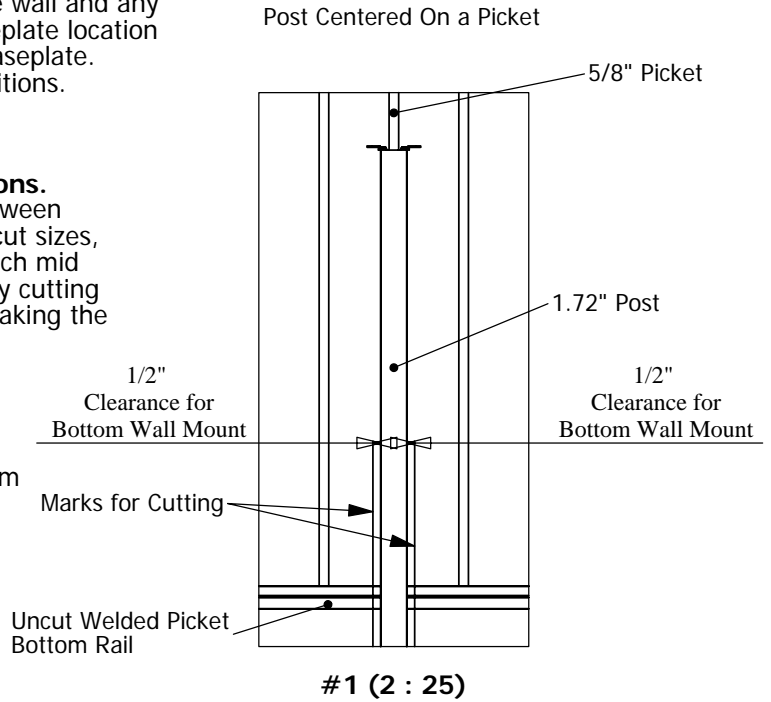
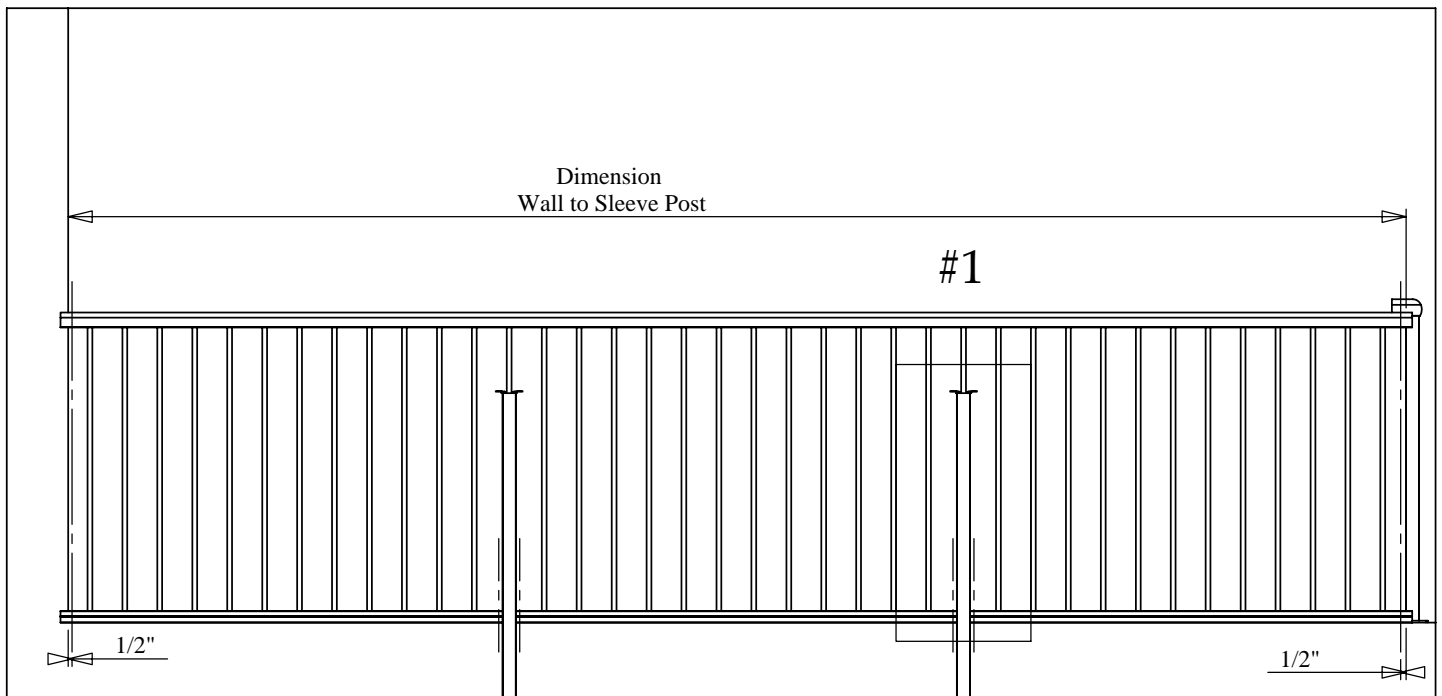

Diagram D



THE MATERIAL CONTAINED HEREIN IS PROPRIETARY TO DECKRITE LLC. AND SHALL NOT BE REPRODUCED, DISCLOSED, OR USED FOR ANY OTHER PURPOSE WITHOUT THE WRITTEN CONSENT OF DECKRITE LLC.

DeckRail

A Product of DeckRite LLC
3912 East Progress
North Little Rock, AR 72114
Phone: (501) 945-1919
Fax: (501) 604-0235



Diagram E

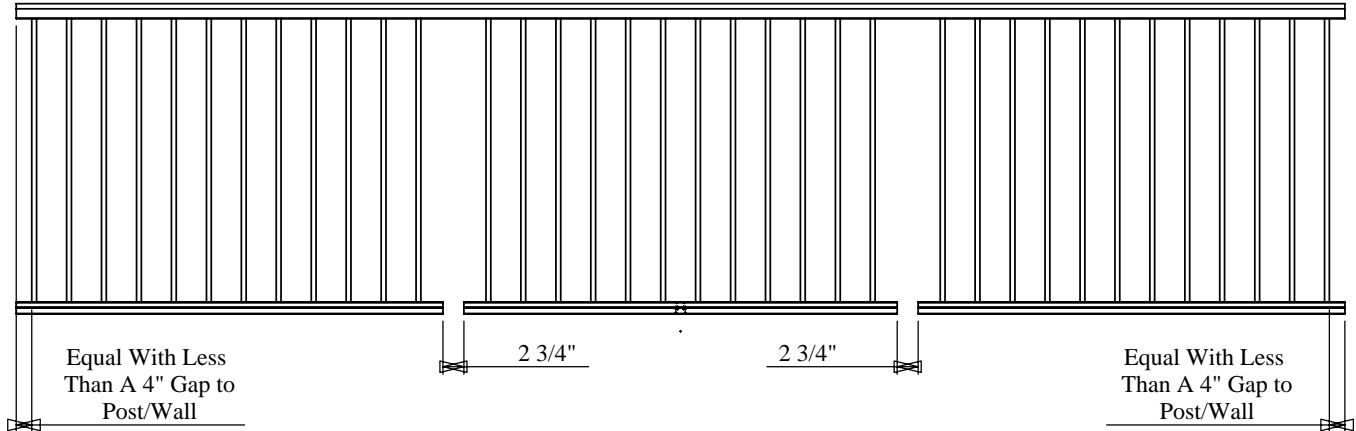

Step 5 Installing Mid Posts

When you have completed cutting out your welded picket panel it should look like the one in Diagram E. Now it's time to attach the mid posts to the welded picket panel. First position your bottom wall mounts overtop of the bottom rail. Then attach the mid posts using 2 - #10 X 3/4" tek screws to fasten the post mount plate to the top rail. Attach the bottom wall mounts to the post using 2 - #10 X 3/4" tek screws per wall mount. Finally attach the bottom wall mounts to the bottom rail. See Diagram F

Diagram F

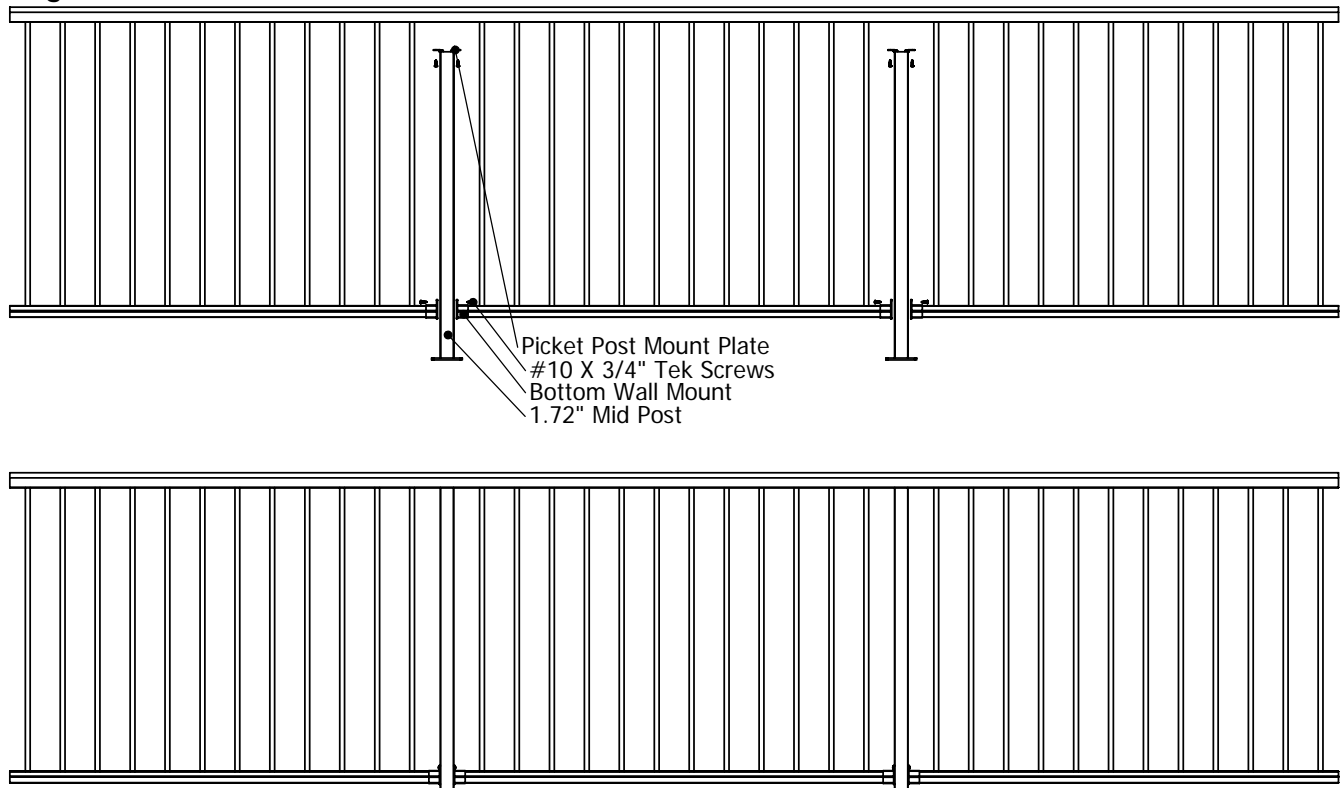

THE MATERIAL CONTAINED HEREIN IS PROPRIETARY TO DECKRITE LLC. AND SHALL NOT BE REPRODUCED, DISCLOSED, OR USED FOR ANY OTHER PURPOSE WITHOUT THE WRITTEN CONSENT OF DECKRITE LLC.

DeckRail

A Product of DeckRite LLC
3912 East Progress
North Little Rock, AR 72114
Phone: (501) 945-1919
Fax: (501) 604-0235

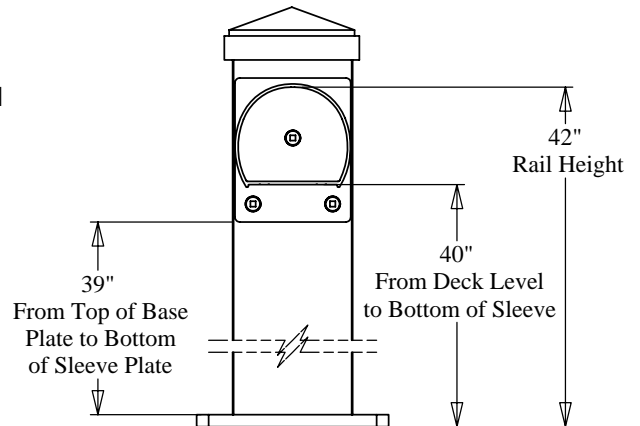

Diagram G

Step 6

Install Top Rail Wall Mounts

At any location where the welded picket panel will attach to a building wall or to a 2 1/2" Post you will need to use top rail wall mounts. The position of the top rail wall mounts can be found either by measuring or by sliding the wall mount over your assembled welded picket panel and posts and then marking where the wall mount lines up to. Once you know where you want the top wall mounts installed, fasten them securely, using approved fasteners. See Diagram H for an example of a wall mount on a 2 1/2" Post.



Step 7

Assembling the deck

Once all the wall mounts are in place its time for final assembly. Start by sliding bottom wall mounts over the open ends of the panels. Then starting from one side of the deck and working your way around the deck, Fit your panels into position. Sliding support legs into place as you go with the hole facing onto the deck, fasten the posts to the deck and fasten the bottom wall mounts to the mounting surface. It may be necessary, if both ends of your deck end in wall mounts, to place both of the last two panels on the deck before fastening down the last sleeve post. At this time make sure and fasten all the top sleeves to the post.

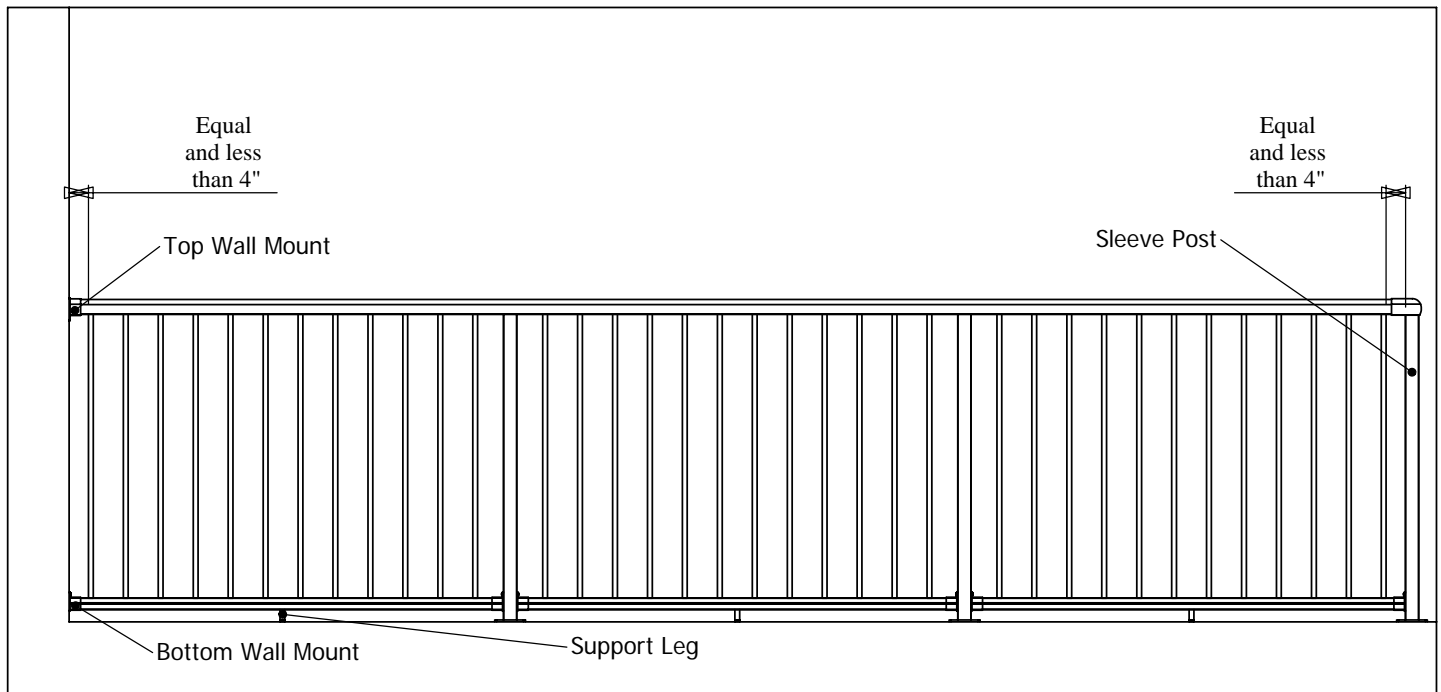

Step 8

Final Inspection

Ensure that all posts are fastened to the deck. Also that all bottom sleeves, top sleeves, and top rails are attached to the posts. That all screws and fasteners are tight and none of them are missing. Make sure all support legs are in place and screwed to the deck.